

MOTOR SPECIFICATION SHEET

MODEL : CHHM5-6135-25 (LT) (Motor model : SF-JRG 5HP 4P)

USED FOR : GEAR MOTOR

DESCRIPTION	DETAIL				
PHASE	3				
MODEL NAME	CHHM5-6135-25				
RATED OUTPUT, HP (kW)	5 (3.7)				
POLE	4				
CODE	MEATH CODE : 1G1025-050N61352				
OUTLINE DRAWING NO.	OMM14O969-*				
RATED VOLTAGE (V)	220	380	415	220	440
RATED FREQUENCY (Hz)	50	50	50	60	60
RATED CURRENT (A)	13.7	7.9	7.7	13.5	7.2
RATED SPEED (min ⁻¹) *	57	57	57	68	69
THERMAL CLASS	155(F)				
RATING	S1 (CONTINUOUS)				
ENCLOSURE CONSTRUCTION	TOTALLY ENCLOSED FAN COOLED				
DEGREES OF PROTECTION	IP55				
METHOD OF COOLING	IC411				
FRAME NO.	112M				
WEIGHT (kg)	74				
STANDARD	IEC 60034-1, JEC-2137-2000				
INSTALLATION	FOOT MOUNTED				
ROTATION	CCW (VIEWED FROM SHAFT END)				
BEARING	LOAD SIDE : 6207ZZ				
	OPPOSITE SIDE : 6206ZZ				
BEARING GREASE	UREA GREASE				
CIRCUMSTANCE CONDITION	AMBIENT TEMPERATURE : -20 ~ +40°C				
	AMBIENT HUMIDITY : 95%RH OR LESS				
	ABOVE SEA LEVEL : 1000m OR LESS				
	ENVIRONMENT : NO BURSTING/EROSIVE GAS OR VAPOR				
COLOR	MUNSELL N5.5 (GRAY)				
TERMINAL BOX	NO. OF LEAD WIRES : 6				
	SOURCE CONNECTION : TERMINAL BLOCK				
INSULATION RESISTANCE	BY DC 500V MEGGER - ≥100MΩ				
DIELECTRIC TEST	AC 50Hz 1800V - 1min. (Based on rated voltage 380V)				
GEAR RATIO	1 : 25				
GEAR LUBRICANT	OIL (Must be filled by user.)				
SERVICE FACTOR	1.55				
MATERIAL	FRAME : STEEL PLATE				
	BRACKET (GEAR SIDE) : CAST IRON				
	BRACKET (OPP SIDE) : ALUMINIUM				
	GEAR CASE : CAST IRON				
	SHAFT (MOTOR) : STEEL				
	SHAFT (GEAR OUTPUT) : STEEL				
	STATOR CORE : ELECTRICAL STEEL				
	WIRE : ENAMELLED COPPER MAGNET WIRE				
	INSULATOR : POLYESTER FILM SATURATED WITH RESIN				
	VARNISH : EPOXY DENATURALIZATION POLYESTER				
	ROTOR CORE : ELECTRICAL STEEL				
	CONDUCTOR : ALUMINIUM				
	TERMINAL BOX : STEEL PLATE				
PAINTING : POLYURETHANE RESIN					
PRODUCTION COUNTRY	THAILAND				

* This value is calculated by MOTOR RATED SPEED / GEAR RATIO.

(Catalog value is specified by follow Gear maker specification, 50/60Hz = 58/70min⁻¹.)

Specifications subject to change without notice.

SPECIFICATION SHEET NO.				
SS-M-1411-A				

MODEL CHHM THREE PHASE INDUCTION MOTOR OUTLINE DRAWING

**GEAR MOTOR
TOTALLY ENCLOSED FAN COOLED
DEGREES OF PROTECTION IP55
DUST & WATER JET PROOF**

CUSTOMER _____
USER _____
FOR _____
CUSTOMER'S ORDER NO. _____
QUANTITY _____
MFG. ORDER NO. _____

ROTATION

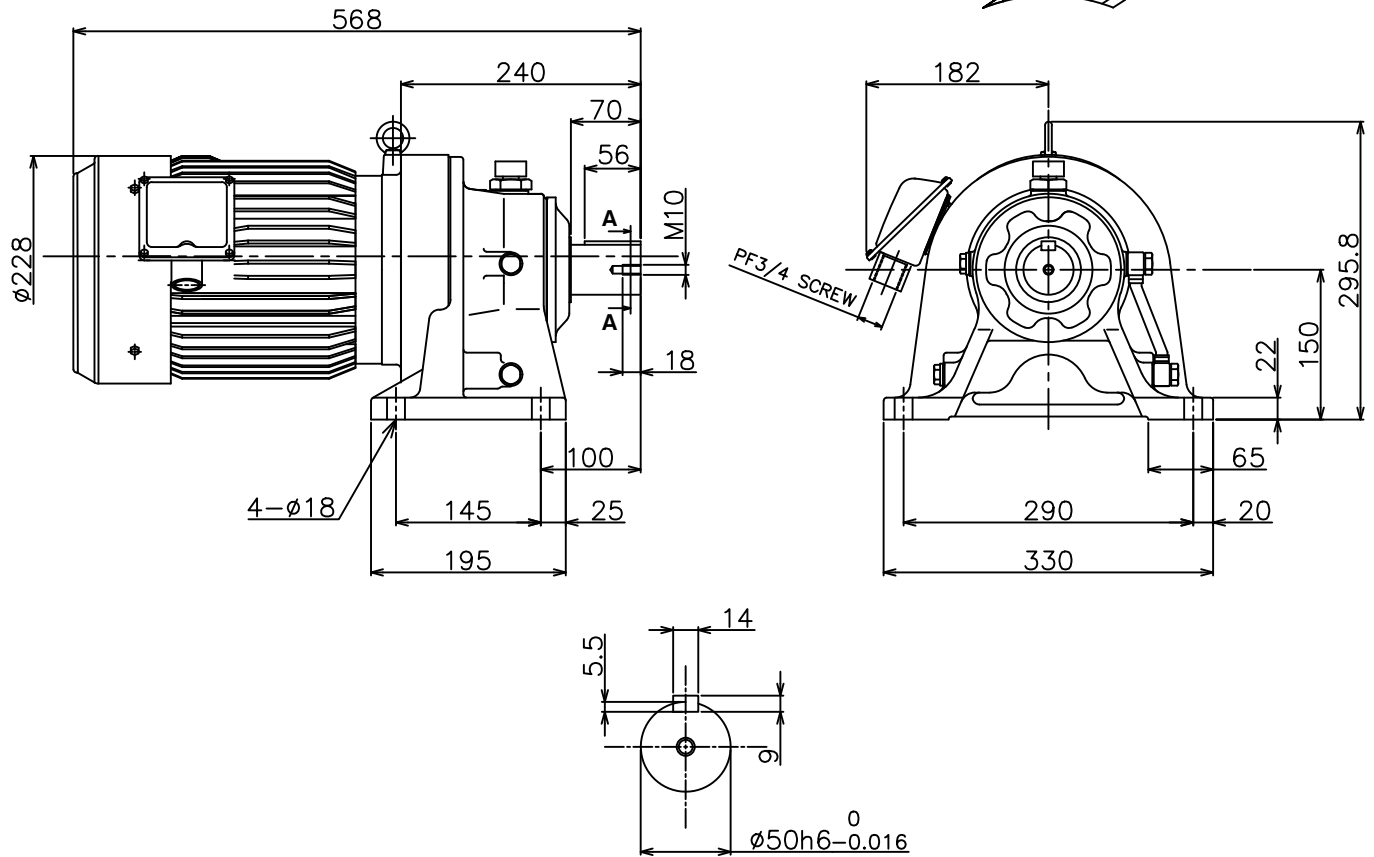

SECTION A-A

YOUR ORDER	MOTOR FRAME SIZE	RATING	TH. CLASS	AMB. TEMP	BEARINGS		COLOR	DIRECTION OF ROTATION	NO. OF LEAD WIRES	REMARKS
					LOAD SIDE	OPP. SIDE				
	112M	S1 (CONT.)	155(F)	40°C	6207ZZ	6206ZZ	GRAY (MUNSELL N5.5)	CCW	6	

YOUR ORDER	MODEL NAME	RATIO	SERVICE FACTOR	MOTOR OUTPUT		POLE	HERTZ	VOLT	OUTPUT SPEED (rpm)	LUBRICATION TYPE	WEIGHT (kg)
				HP	kW						
	CHHM5-6135-25	1:25	1.55	5	3.7	4	50 60	220/380/415 220/440	58 70	OIL (1)	74
	CHHM5-6135-29	1:29	1.31	5	3.7	4	50 60	220/380/415 220/440	50 60		
	CHHM5-6135-25	1:25	1.55	5	3.7	4	50 60	380/415 380/440	58 70		
	CHHM5-6135-29	1:29	1.31	5	3.7	4	50 60	380/415 380/440	50 60		

NOTE : (1) Please fill in Oil before first time usage (See detail in the Instruction Manual)

MITSUBISHI ELECTRIC AUTOMATION (THAILAND) CO., LTD.

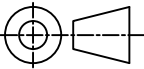
		OUTLINE DRAWING NO. OMM 1 4 0 9 6 9	REV. *	
	DIMENSION IN mm.			
	SCALE : NTS			